

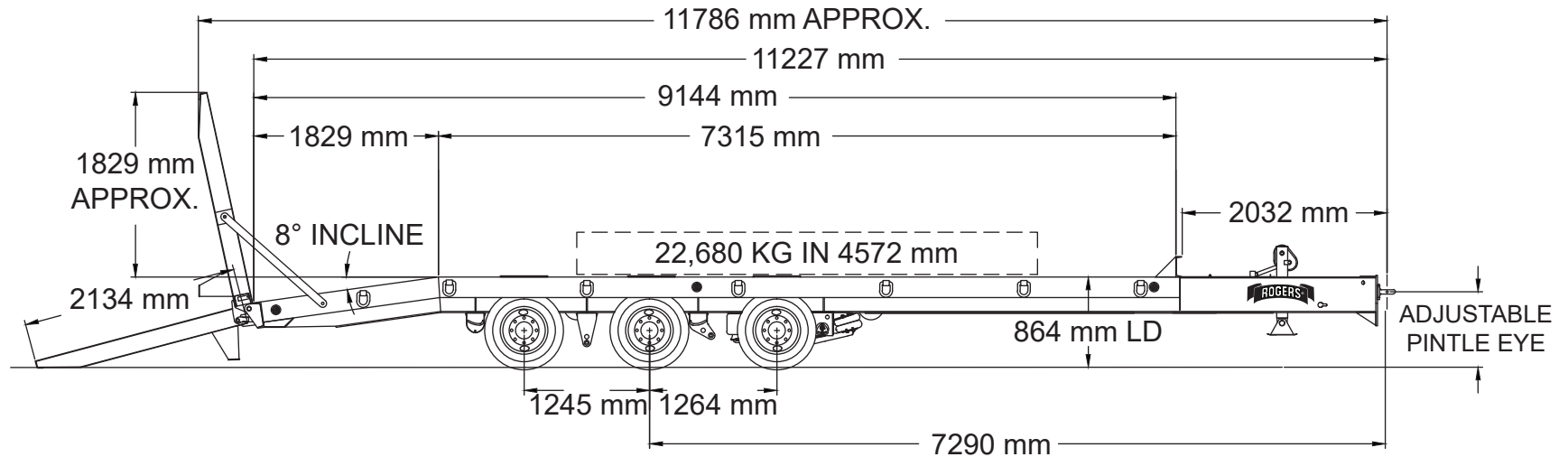

## TAG25XXL-AL Tag-Along Trailer with Air Ramps Code 413-012

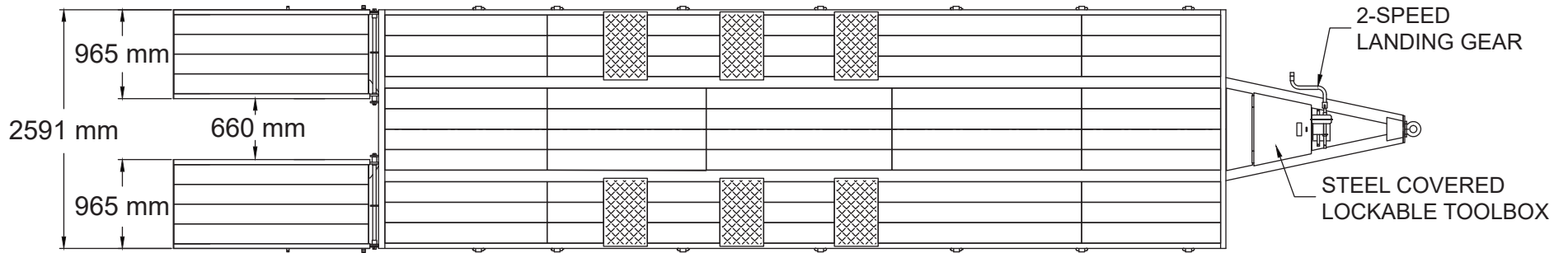

### ROGERS BROTHERS CORPORATION

100 Orchard Street  
Albion, PA 16401 USA  
www.rogerstrailers.com

Toll Free: 800-441-9880  
Phone: 814-756-4121  
FAX: 814-756-4830

Copyright © 2018 Rogers Brothers Corporation

NOTES: ALL ILLUSTRATIONS, WEIGHTS, AND SPECIFICATIONS ARE APPROXIMATE. THESE MAY VARY WITH MODEL CHANGES AND ARE SUBJECT TO ENGINEERING REVISION AS REQUIRED.