

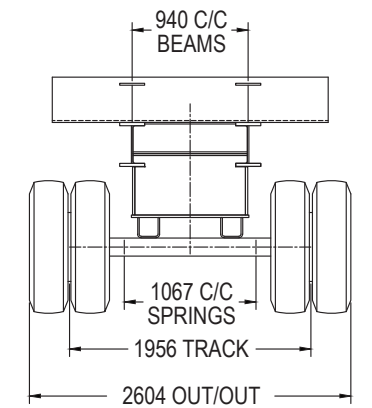

SP100CT - 100-ton Coil Trailer

Model Code: 105-006

Note: All Dimensions in MM

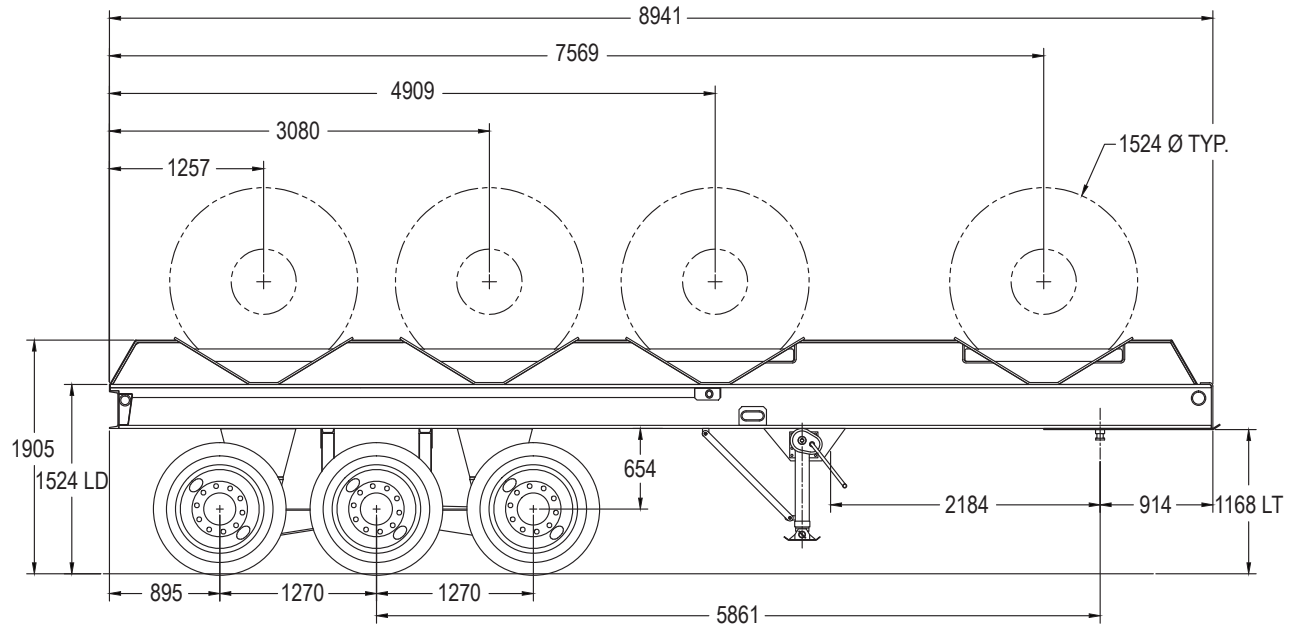
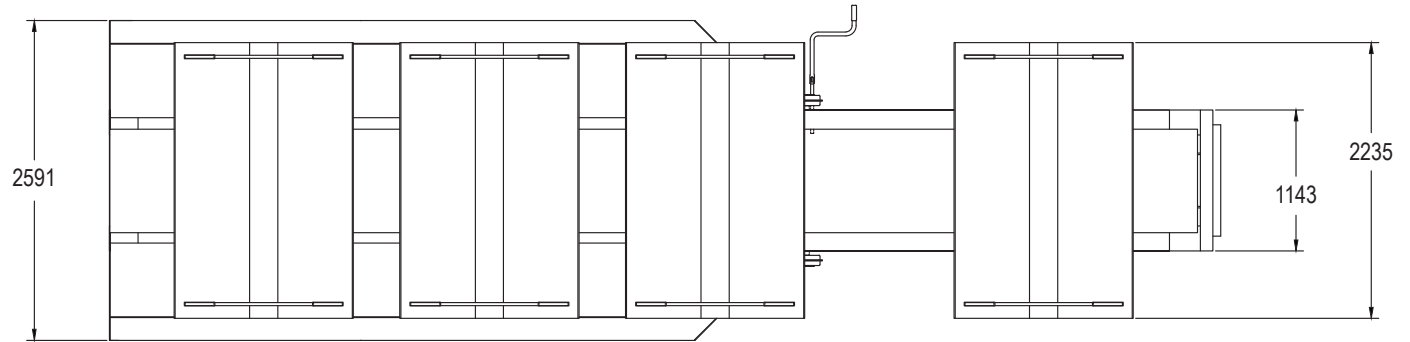

SECTION AT SUSPENSION MOUNT

[12] - 315/80R22.5(L) TUBELESS RADIAL TIRES
3-AXLE SPRING/WALKING BEAM SUSPENSION

ROGERS BROTHERS CORPORATION

100 Orchard Street
Albion, PA 16401 USA
www.rogerstrailers.com

Toll Free: 800-441-9880
Phone: 814-756-4121
FAX: 814-756-4830

Copyright © 2018 Rogers Brothers Corporation

NOTES: ALL ILLUSTRATIONS, WEIGHTS, AND SPECIFICATIONS ARE APPROXIMATE. THESE MAY VARY WITH MODEL CHANGES AND ARE SUBJECT TO ENGINEERING REVISION AS REQUIRED.