



FIXED GOOSENECK SERIES

25 TON MACHINERY HAULER



SOME OPTIONAL EQUIPMENT MAY BE SHOWN.

The ROGERS® **FIXED GOOSENECK MH25** – a "carry all" trailer with the combined conveniences of a rear loading style, a spacious level deck, and sloped access to the full-width gooseneck. It is a gooseneck style that can hold machine equipment or a cargo load. This 25-ton Machinery Hauler has the streamline dependability to provide trouble-free service.

STANDARD FEATURES



■ **Long, flat gooseneck and durable pin type landing legs.** The gooseneck beams are constructed of 100,000 psi minimum yield steel to maximize strength and minimize weight. The full-width gooseneck is oak-covered and has a tool box with an oak lid for storing tools and chains. The pin type landing legs are easy to use and have the static capacity of 40,000 lbs.

■ **Unitized frame construction.** Main beams are fabricated of 100,000 psi minimum yield steel. Ten-inch deep cross members are pierced through the main beams for a lower deck height and stronger frame. The deck is a full 1 3/4" thick air-dried oak. The multi-leaf four-spring suspension provides a stable ride. Both axles have spring brakes and a premium 4S/2M anti-lock braking system.



■ **Rear frame has trunnions between wheels and LED lights package.** The 14° sloped beavertail has "E-Z Flip" loading ramps constructed of high strength steel, yet are light enough for easy operation with dual springs to assist lifting. Plus these ramps have easy lateral adjustments to handle machines of various widths. Standard ramps are oak-covered: photo shows optional ladder style.

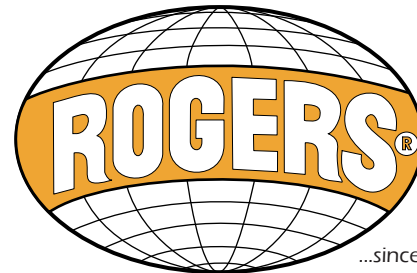

...since 1905

THE ULTIMATE IN TRAILERS®

ROGERS BROTHERS CORPORATION

www.rogerstrailers.com

The name you know, experience you can trust and the performance to back it up.

25 TON FIXED GOOSENECK • MH25

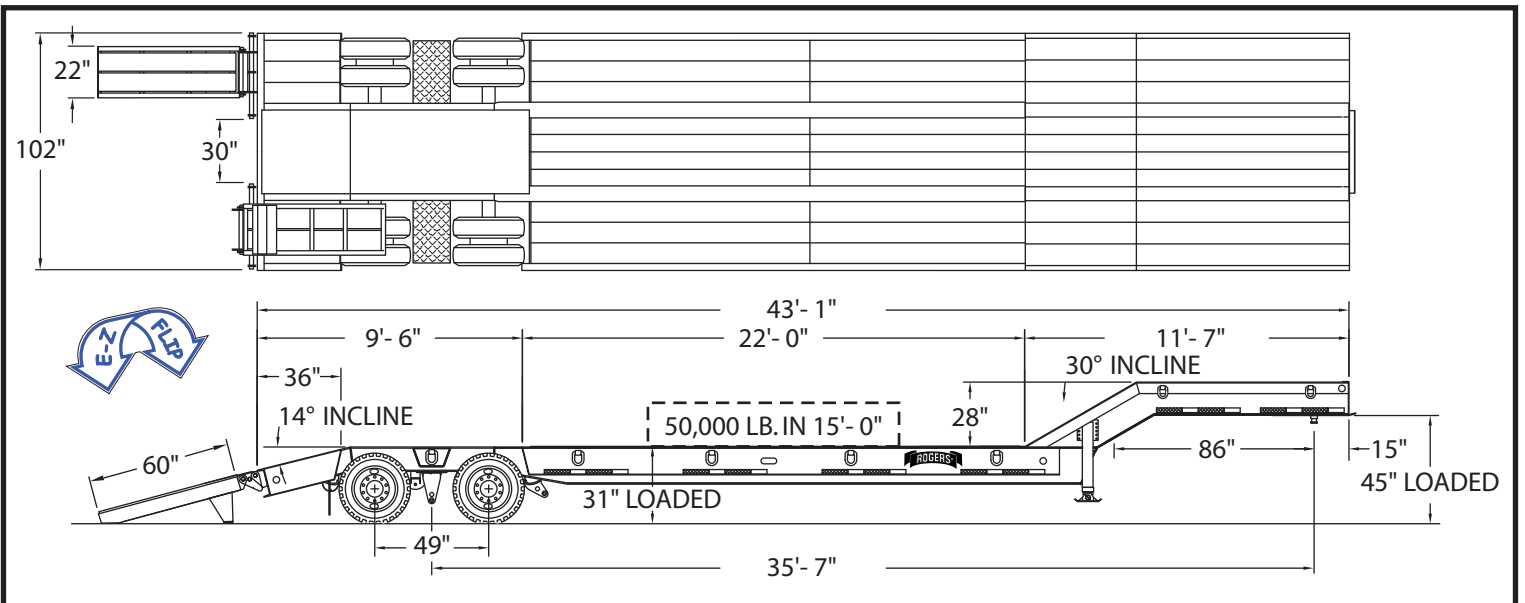

SPECIFICATIONS	Maximum Structural Capacity	Suspension	Axles	Tires	Wheels & Rims	Air Brakes	Landing Gear	Empty Weight	Gross Vehicle Weight Rating	Gross Axle Weight Rating
	25 tons in 15'-0" of the deck	Multi-leaf four-spring Capacity: 44,800 lbs	5" round Capacity: 22,500 lb @ 60 mph	215/75R17.5(H) low-profile tubeless radial Capacity: 18,180 lb	17.5" x 6.75" hub-piloted 8-hole steel disc wheels on 12 1/4" x 7 1/2" drum	Rising "S" cam style 4S/2M ABS with spring parking brakes	Pin Type Static load: 40,000 lb	12,980 lb	62,980 lb	18,180 lb @ 60 mph

STANDARD FEATURES

- Gooseneck swing radius 86"; 5th wheel 45" loaded.
- Gooseneck toolbox with oak lid.
- Oak-covered 30° slope from deck to gooseneck.
- Fourteen (14) bent lashing D's.
- Oak-covered 36" beavertail with 14° slope.
- Center rear frame 1/4" smooth cover plate.
- Oak-covered "E-Z Flip" rear loading ramps, 60" x 22" laterally adjustable.
- LED Lights: US DOT-approved 12-volt rubber-mounted with sealed wiring and 7-wire socket.
- Epoxy primer; ROGERS Red or Black enamel finish.

OPTIONAL EQUIPMENT

- Two-speed landing gear package.
- Gooseneck toolbox with lockable steel lid.
- Additional lashing D's.
- Ladder-style "E-Z Flip" rear loading ramps.
- Hydraulic rear ramps.
- Aluminum disc wheels.
- 235/75R17.5(H)16 low-profile tires.
- Mechanical backup warning alarm.
- Hubodometer
- Other ROGERS paint colors available.



...since 1905

ROGERS BROTHERS CORPORATION

100 Orchard Street
Albion, Pennsylvania, 16401
(800) 441-9880
(814) 756-4121
(814) 756-4830 FAX
www.rogerstrailers.com

In keeping with our policy of constant improvement, the designs, materials, and specifications are subject to change without notice or penalty. Capacity ratings are frame ratings only. Actual load capacities may be restricted by factors such as gross axle weight ratings (GAWR) and/or state and federal regulations.