



OIL FIELD SERIES

40 TON CAPACITY



SOME OPTIONAL EQUIPMENT MAY BE SHOWN.

ROGERS® offers the unique **OIL FIELD OF40L** – a heavy-duty 40-ton capacity trailer. It features a rear tail roller and a spacious 35-foot level deck. This trailer's field-tested design will handle the "work horse" duties needed in oil and natural gas exploration.

STANDARD FEATURES



■ Heavy-duty main beams and side channels with deep cross members combine to make a strong and durable trailer frame. The heavy-duty undercarriage includes flip-leg landing gear and single-point, two-spring suspension. Both axles have spring parking brakes and a premium 4S/2M anti-lock braking system.

■ The OF40L trailer has a rounded front designed with an attachment for winch lifting. It has a pair of recessed air line glad hands that are retractable so cleaning off dirt and mud is easier.



■ The rear design of the trailer has dozer push bars and a tow ring. It features a heavy-duty 8" diameter "tail roller" built with bushings for durability. Other standard features are (18) pipe pockets, removable mud flaps, and 1 3/4" air-dried oak decking installed with carriage bolts and cupped washers.

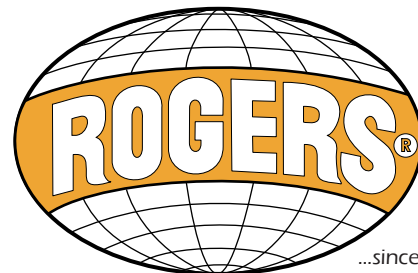

THE ULTIMATE IN TRAILERS®

ROGERS BROTHERS CORPORATION

www.rogerstrailers.com

The name you know, experience you can trust and the performance to back it up.

40 TON OIL FIELD SERIES • OF40L

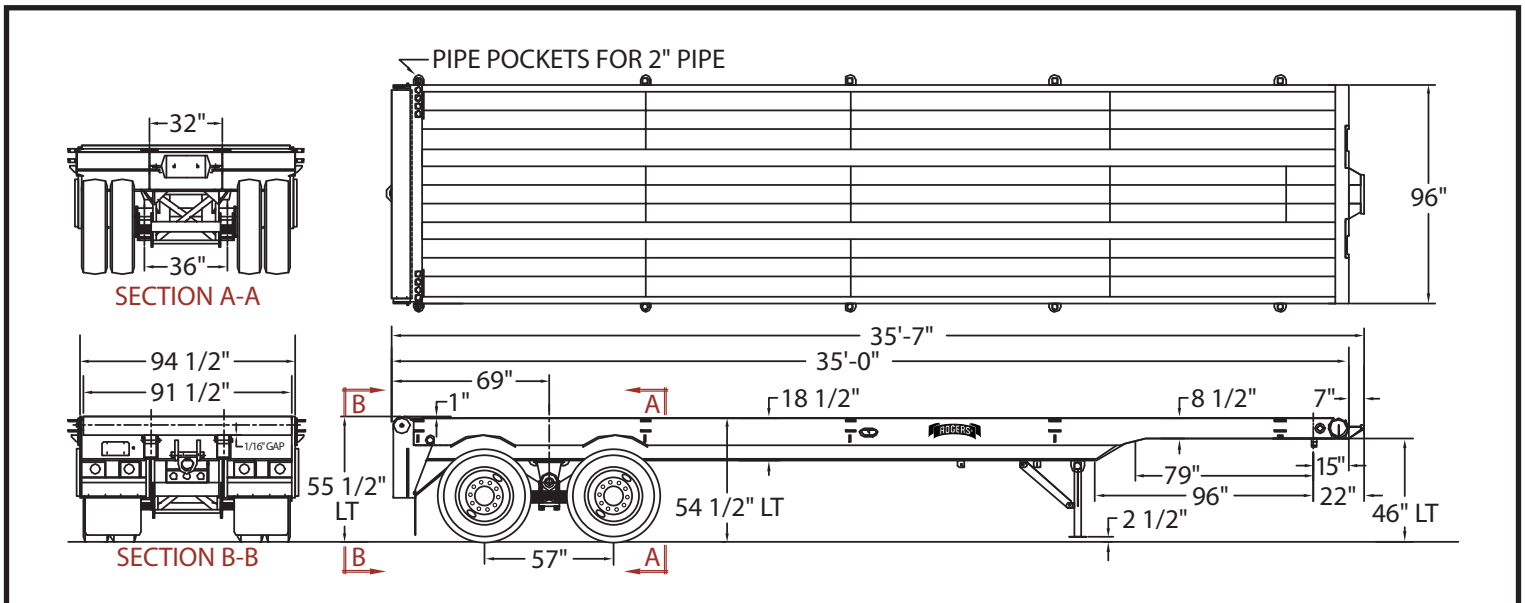

SPECIFICATIONS	Maximum Structural Capacity	Suspension	Axles	Tires	Wheels & Rims	Air Brakes	Landing Gear	Empty Weight	Gross Vehicle Weight Rating	Gross Axle Weight Rating
	40 tons in 17'-6" of the deck	Heavy-duty single point, two-spring Capacity: 50,000 lbs	5" round Capacity: 25,000 lb @ 60 mph	11R22.5 (H) tubeless radial Capacity: 24,020 lb	22.5" x 8.25" hub-piloted 10-hole steel disc wheels on 16 1/2" x 7" drum	Rising "S" cam style 4S/2M ABS with spring parking brakes	Heavy-duty flip-leg	17,670 lb	97,670 lb	24,020 lb @ 60 mph

STANDARD FEATURES

- 5th wheel height 46" light.
- Eighteen (18) pipe pockets: (5) per side, (8) on rear.
- 1 3/4" oak deck.
- Heavy-duty flip leg landing gear.
- Recessed, retractable air lines.
- Removable mud flaps.
- Rear 8" roller with bronze bushings.
- Rear severe-duty dozer push bars and 1" tow ring.
- Lights: US DOT-approved 12-volt, rubber-mounted with sealed wiring system and 7-wire socket.
- Epoxy primer; ROGERS Red enamel finish.

OPTIONAL EQUIPMENT

- 60,000 lb. multi-leaf, single point suspension.
- LED lights package.
- Mechanical backup warning alarm.
- ROGERS Black enamel finish.
- Other ROGERS paint colors available.

ROGERS BROTHERS CORPORATION

100 Orchard Street
 Albion, Pennsylvania, 16401
 (800) 441-9880
 (814) 756-4121
 FAX (814) 756-4830
 www.rogerstrailers.com



In keeping with our policy of constant improvement, the designs, materials, and specifications are subject to change without notice or penalty. Capacity ratings are frame ratings only. Actual load capacities may be restricted by factors such as gross axle weight ratings (GAWR) and/or state and federal regulations.