



FIXED GOOSENECK SERIES

35 TON CAPACITY TVT



SOME OPTIONAL EQUIPMENT MAY BE SHOWN.

The ROGERS® **FIXED GOOSENECK TVT35** – streamline dependability in a 35-ton capacity trailer. It features the convenience of a rear loading style with a spacious level deck. The long, flat fixed gooseneck easily accommodates equipment buckets and blades. This trailer will provide reliable, trouble-free service.

STANDARD FEATURES



■ **Long, flat gooseneck and durable pin type landing legs.** The gooseneck beams are constructed of 100,000 psi minimum yield steel to maximize strength while minimizing weight. Open area in the center of gooseneck provides ample room for chain and tool storage. The pin type landing legs are durable (40,000 lb. static capacity) and easy to use. Full 2" thick air-dried oak deck is fastened to the frame with bolts and cupped washers.

■ **Unitized frame construction.** Main beams are fabricated of 100,000 psi minimum yield steel. Ten-inch deep cross members are pierced through the main beams for a lower deck height and stronger frame. The multi-leaf four-spring suspension provides a stable ride. Both axles have spring brakes and a premium 4S/2M anti-lock braking system.



■ **"E-Z Flip" loading ramps with 14° beavertail.** These ramps are constructed from high strength steel, yet are light enough for easy operation. Dual springs assist lifting the ramps off the ground, as well as off the deck, and they can be easily adjusted laterally to allow machines of various widths to be loaded. Available in standard oak-covered or optional ladder style.



...since 1905

THE ULTIMATE IN TRAILERS®

ROGERS BROTHERS CORPORATION

www.rogerstrailers.com

The name you know, experience you can trust and the performance to back it up.

35 TON FIXED GOOSENECK • TVT35

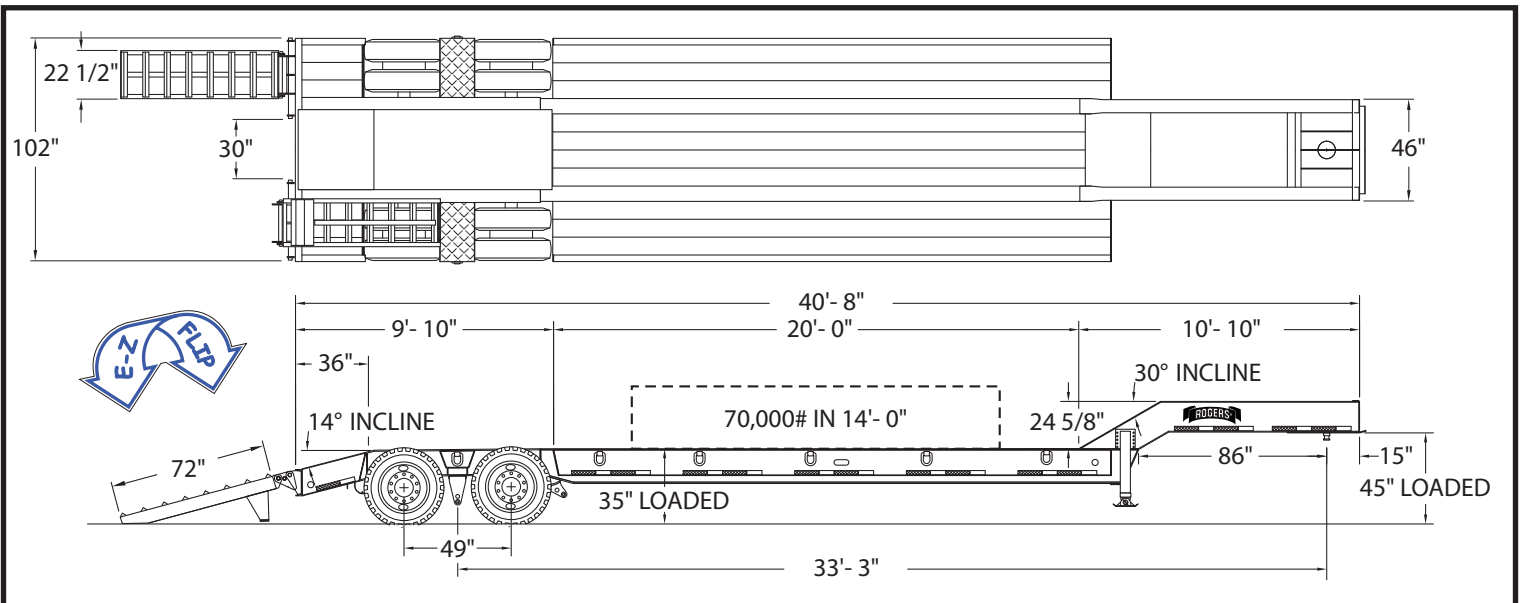

SPECIFICATIONS	Maximum Structural Capacity	Suspension	Axles	Tires	Wheels & Rims	Air Brakes	Landing Gear	Empty Weight	Gross Vehicle Weight Rating	Gross Axle Weight Rating
	35 tons in 14'-0" of the deck	Multi-leaf four-spring Capacity: 50,000 lbs	5" round Capacity: 22,500 lb @ 60 mph	255/70R22.5(H) low-profile tubeless radial Capacity: 20,280 lb	22.5" x 8.25" hub-piloted 10-hole steel disc wheels on 16 1/2" x 7" drum	Rising "S" cam style 4S/2M ABS with spring parking brakes	Pin Type Static load: 40,000 lb	11,900 lb	81,900 lb	20,280 lb @ 60 mph

STANDARD FEATURES

- Gooseneck swing radius 86"; 5th wheel 45" loaded.
- Storage area in gooseneck over king pin.
- Twelve (12) bent lashing D's.
- Oak-covered 36" beavertail with 14° slope.
- Oak-covered "E-Z Flip" rear loading ramps, 72" x 22 1/2" laterally adjustable.
- LED Lights: US DOT-approved 12-volt rubber-mounted with sealed wiring and 7-wire socket.
- Epoxy primer; ROGERS Red or Black enamel finish.

OPTIONAL EQUIPMENT

- Two-speed landing gear package.
- Gooseneck fenders (splash protection only).
- Motor grader ramps.
- Full-width gooseneck, oak decking on top only.
- Additional lashing D's.
- Ladder-style "E-Z Flip" rear loading ramps.
- Hydraulic rear ramps.
- Aluminum disc wheels.
- Mechanical backup warning alarm.
- Other ROGERS paint colors available.



...since 1905

ROGERS BROTHERS CORPORATION

100 Orchard Street
 Albion, Pennsylvania, 16401
 (800) 441-9880
 (814) 756-4121
 (814) 756-4830 FAX
www.rogerstrailers.com

In keeping with our policy of constant improvement, the designs, materials, and specifications are subject to change without notice or penalty. Capacity ratings are frame ratings only. Actual load capacities may be restricted by factors such as gross axle weight ratings (GAWR) and/or state and federal regulations.